

NCS-C240 Multi-Switcher™ INSTRUCTION MANUAL



New Communications Solutions, LLC
5364 Valley Mist Trace
Suite 101
Norcross, Georgia 30092

Toll Free Tel. & Fax : 888- 883-5788
Email : support@ncsradio.com
Web Site: www.ncsradio.com



Introduction

The Multi-Switcher™ was designed to provide a method to switch multiple microphones, headsets and foot- or hand-switch to multiple radios. The Multi-Switcher™ makes it simple to switch between different radios without having to connect and disconnect cables. It works with nearly any microphones and radios and can switch up to four microphones, headsets or other audio sources to any of four radios. Provision is included for setting pin assignments, impedance level and electret mic element voltage for each input.

The Multi-Switcher™ will benefit just about any radio installation. Its flexibility and versatility make it ideal for temporary dispatch positions, emergency operations, mobile communications vans and many other communications environments.

IMPORTANT: This is a complex piece of equipment. Setup is not difficult; however, accurate jumper settings, correctly wired cables and proper connections to other equipment are necessary to get the best performance. Incorrect setup or cable wiring may cause problems such as excessive noise or hum on transmitted signals or the remote possibility of damage to this or attached equipment. Also, attention must be given to the section on Receive Audio to avoid the possibility of hearing damage when using headphones.

1.0 Power Supply

1.1 Power Requirements

The NCS-C240 Multi-Switcher will operate with any 12-15 VDC power supply capable of providing at least 0.5A continuous.

1.2 Power Connection

Power is supplied to the pigtail on the rear of the unit. The connector is an Anderson Powerpole PP-15. As part of the accessory kit, a 10 foot power cable is supplied with a mating connector attached. Connect the power cable to a 12-15VDC source capable of supplying at least 0.5A. Additional connectors are available from Powerwerx (web site: <http://www.powerwerx.com>, telephone: 714.570.3303)

1.3 Polarity

Power cable polarity is: Red = +, Black = - (or chassis ground).

1.4 Fusing

Both power supply lines are fused with fast-acting 3A 5x20 mm fuses (Wickmann USA series 191 or equivalent).

1.5 Using an AC Power Supply

When using a bench type power supply choose a supply that is regulated and has an output no greater than 15 VDC max and a continuous current rating of 0.5A or greater.

If it is desirable to use a Wall Power Supply **be sure that it's output voltage, when connected to the Multi-Switcher, does not exceed 15 VDC.** Many of the Wall Power Supplies on the market that are advertised as 12 VDC are not regulated and may exceed 15 VDC output.

2.0 Microphone and AUX Connections and Setup

The main circuit board inside the Multi-Switcher™ has provisions for setting up the microphone and auxiliary input circuit functions. To setup these functions, remove the cover of the Multi-Switcher™ and refer to the diagram below for the locations of settings and adjustments.

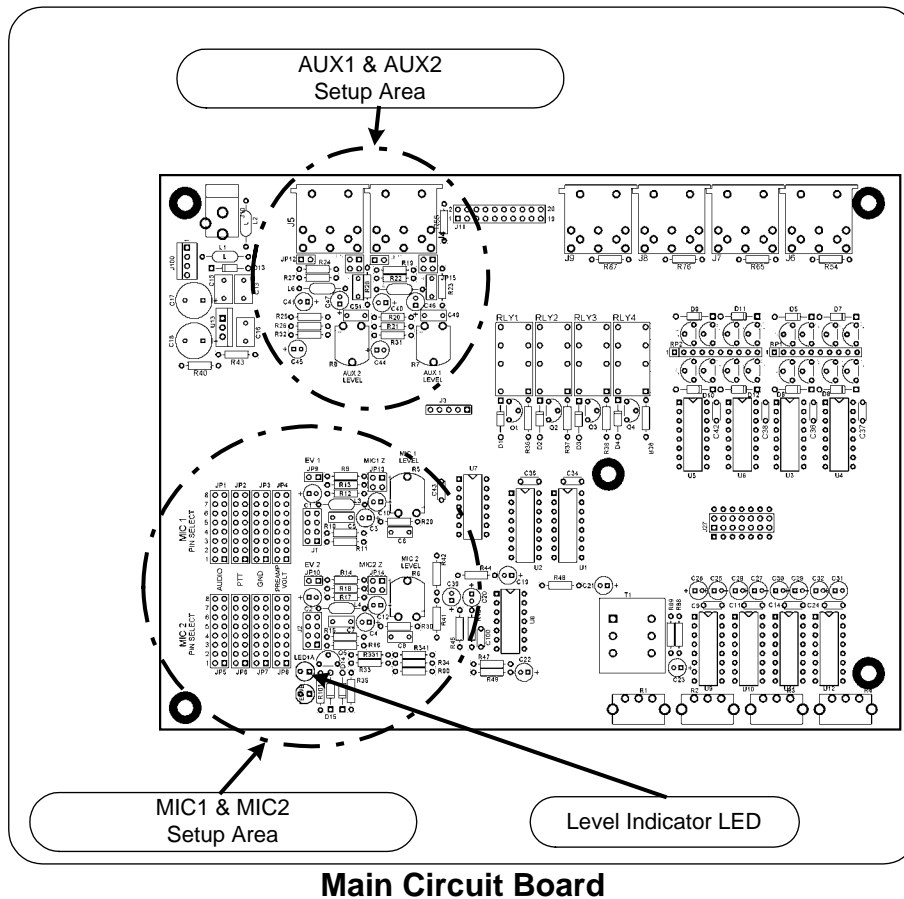

2.1 Front Panel Microphone Connections

The two “Mic” connectors on the front panel accept standard 8-pin Foster microphone plugs. The function of each pin is programmable using the shunts on the main circuit board inside the Multi-Switcher™. This allows the use of nearly any microphone. If your microphone doesn’t use a standard 8-pin Foster connector, then install an adapter from your microphone connector to a standard 8-pin microphone connector.

IMPORTANT: Once you have programmed a microphone connector for a specific microphone, you must use only that microphone type on that connector unless you re-program the connector.

2.1.1 Programming the Microphone Connectors

Programming the microphone connectors is accomplished by setting the microphone connector pin functions, selecting the impedance level and connecting a voltage supply pin if using an electret microphone element

The diagram below shows the Microphone Setup Area of the main circuit board. Refer to it for the following steps.

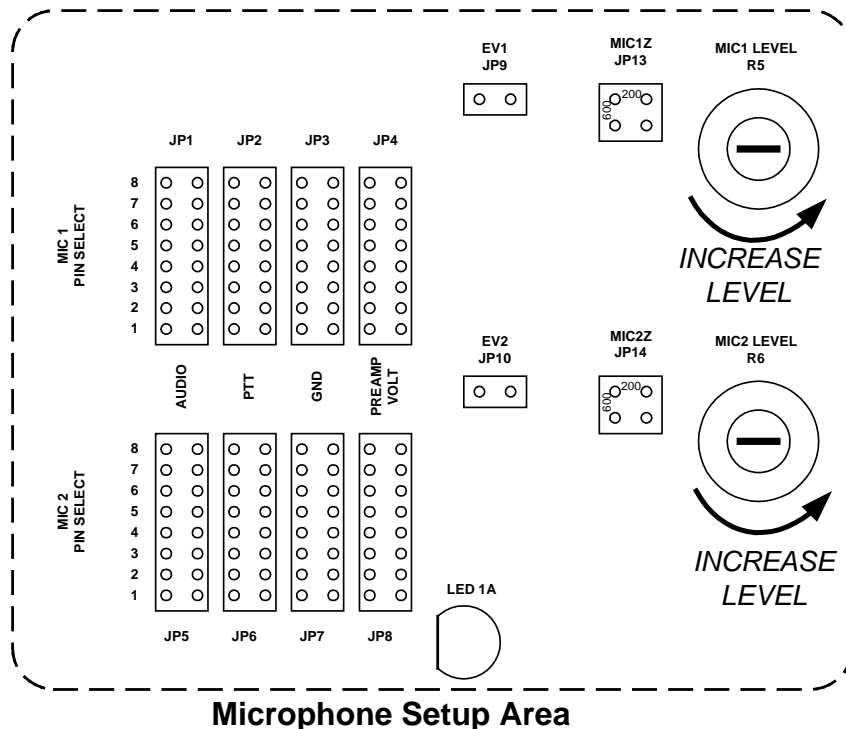

To program the functions of the pins on the front panel microphone connectors, using the shunts supplied in the accessory pack, jumper the appropriate microphone pin numbers to the corresponding signals on the MIC1 or MIC2 PIN SELECT headers.

For example, to program a particular microphone with the pin-outs shown in the table below, you would set the PIN SELECT shunts as shown here:

Example Only – You must set the jumpers for your specific microphone.

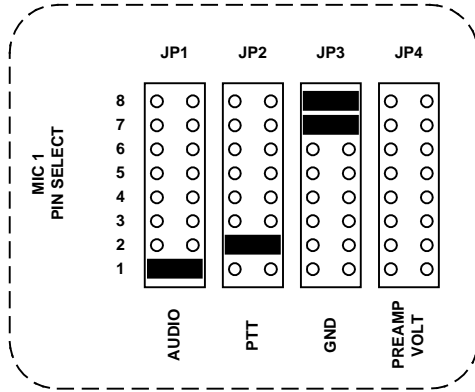

Example Microphone Pin-out

Pin 1	Microphone
Pin 2	Push To Talk (PTT)
Pin 7	Microphone Ground
Pin 8	PTT Ground

Next, select the microphone impedance using shunts on the MIC1Z or MIC2Z jumpers as shown in these examples for Mic1:

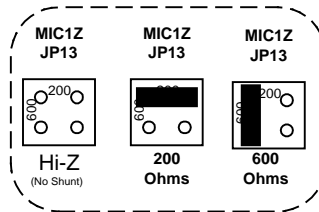

Now, if the microphone is an Electret type that needs a voltage supply, install a shunt on EV1 (Mic1) or EV2 (Mic2):

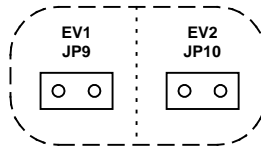

2.2

Rear Panel Auxiliary Connections

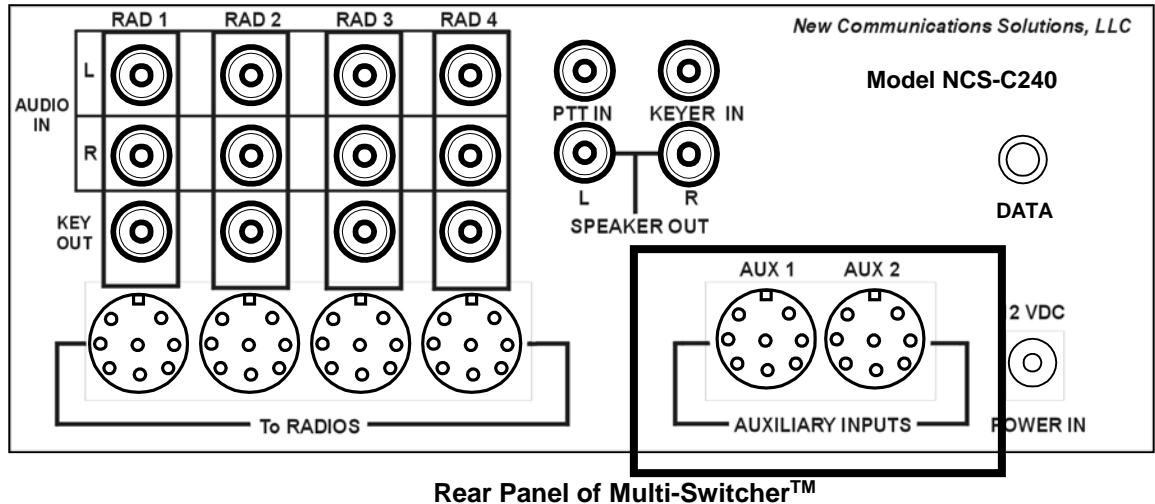

The AUX1 and AUX2 connectors on the rear panel can be used to supply nearly any audio or control signal to the Multi-Switcher™ in the same manner as with the MIC connectors. The only difference is that you don't have to program the pin assignments internally since you assign pin functions when you wire the cable to the AUX mating connectors. **IMPORTANT: Be careful to wire the connector correctly because incorrect wiring will result in improper operation and possible damage to the Multi-Switcher or attached radio.** The pin assignments for the AUX1 and AUX2 connectors are shown in the chart below:

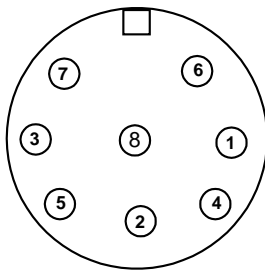

8-pin male DIN connector
solder side

Pin 1	Audio In
Pin 2	PTT In
Pin 3	Preamp Voltage
Pin 4	Receive Audio, Left Channel
Pin 5	Receive Audio, Right Channel
Pin 6	Ground
Pin 7	Ground
Pin 8	Ground

AUX1 and AUX2 Pin Assignments

The diagram below shows the area of the main circuit board where AUX1 and AUX2 setup adjustments are made. Refer to it for the following steps.

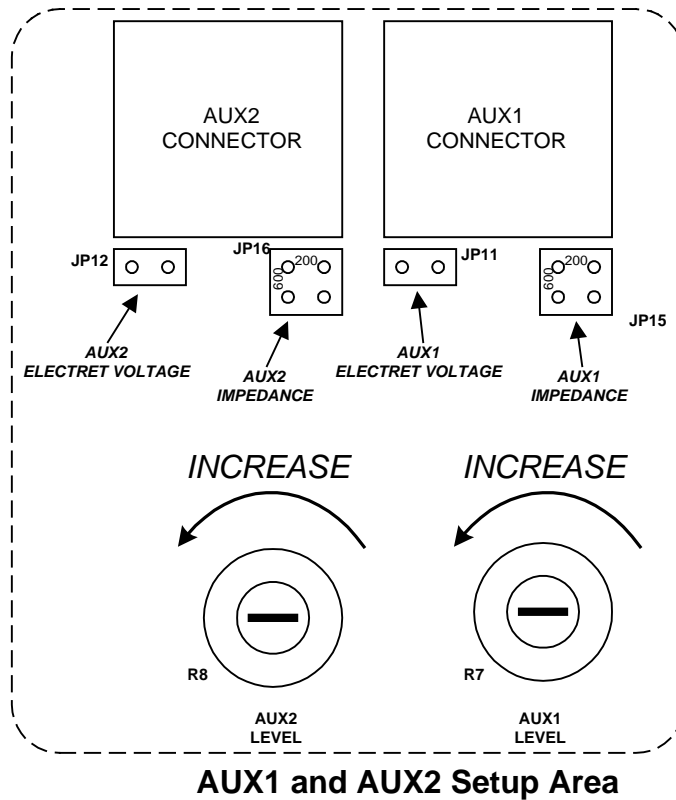

First, select the audio source impedance using shunts on the AUX1 (JP15) or AUX2 (JP16) jumpers as shown in these examples:

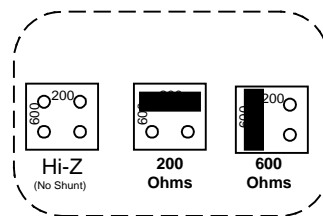

If the audio source is an electret type microphone that needs a voltage supply, install a shunt on JP11 (AUX1) or JP12 (AUX2).

3.0 Radio Connections

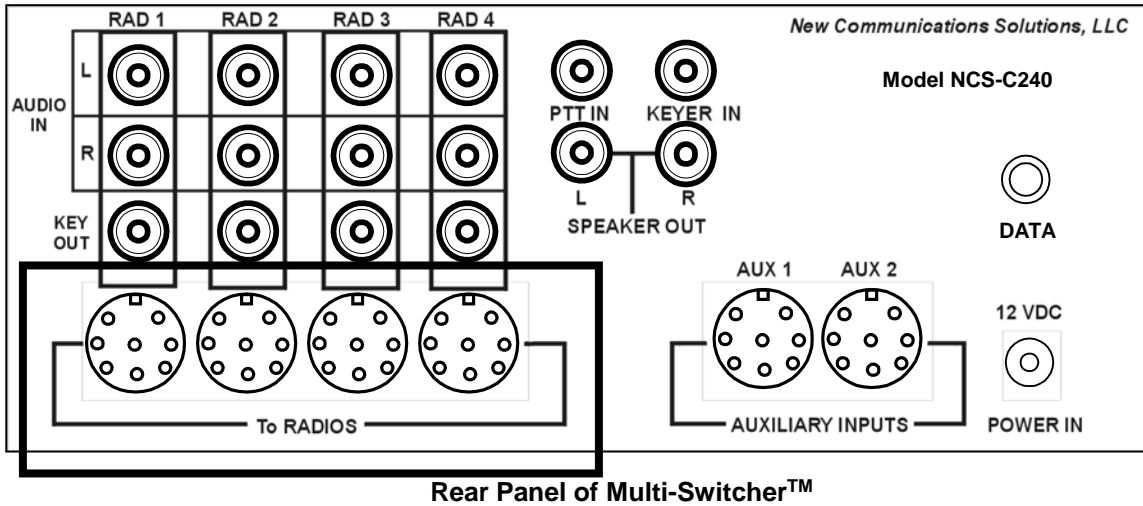

On the rear panel are four 8-pin DIN female connectors that are used to connect the Multi-Switcher™ to 4 different radios. The pin-outs for the DIN connectors are shown below.

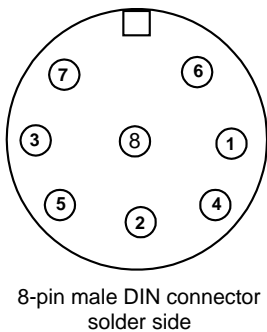

Pin 1	Push To Talk (PTT)
Pin 2	Mic Audio, Common
Pin 3	Mic Audio, High Impedance
Pin 4	Mic Audio, Low Impedance
Pin 5	Ground for PTT and Audio from Radio
Pin 6	Audio from Radio, Right Channel
Pin 7	+12VDC for NCS accessories only . **
Pin 8	Audio from Radio, Left Channel

** +12VDC normally disabled; contact NCS for info

Radio Connector Pin Assignments

4.0 Receive Audio Connections

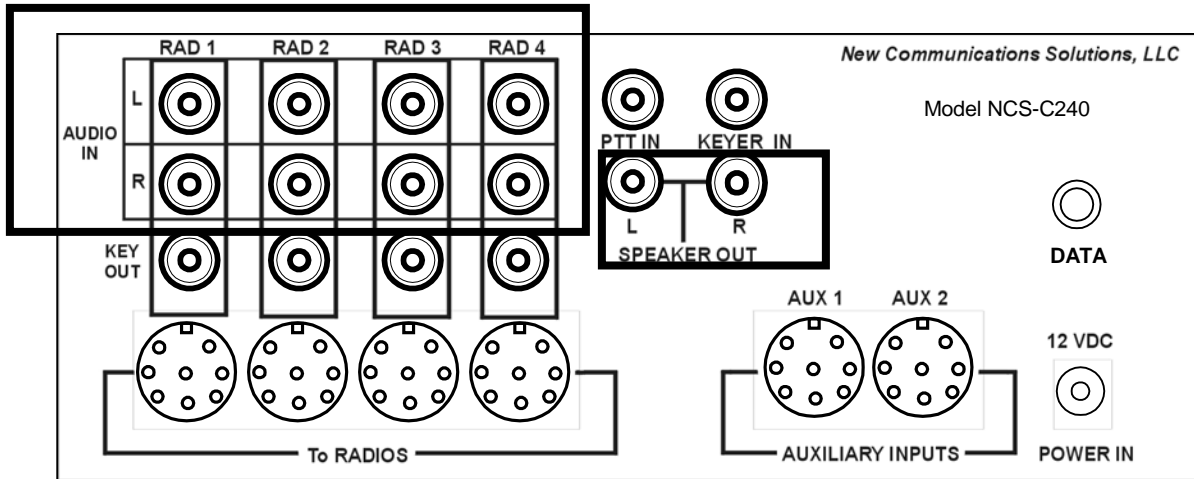

Rear Panel of Multi-Switcher™

The Multi-Switcher™ was designed to switch 2 independent receive audio channels from each radio. This allows switching of Main and Sub audio for radios with this feature.

CAUTION: For maximum flexibility, the Multi-Switcher is designed to work with receive audio from either the Speaker output or Headphone output of your radios. When connecting to the radio's Speaker output, use care with the radio's volume setting when using headphones plugged into the Multi-Switcher. Speaker output levels from many radios can be set high enough to cause pain or hearing damage when using headphones. This is not usually a problem when using the radio's Headphone output since most modern radios attenuate the audio at the headphone jack. In any case, the best advice is to always turn the radio volume down before putting on headphones.

There are two ways to connect to the receive audio from a radio. The first is using the RCA Phono jacks on the rear of the Multi-Switcher™. For each radio, there is a Left and Right connection. For radios with only a single receive audio output channel, use a Y-cable, obtained locally, to tie both channels together as shown below:

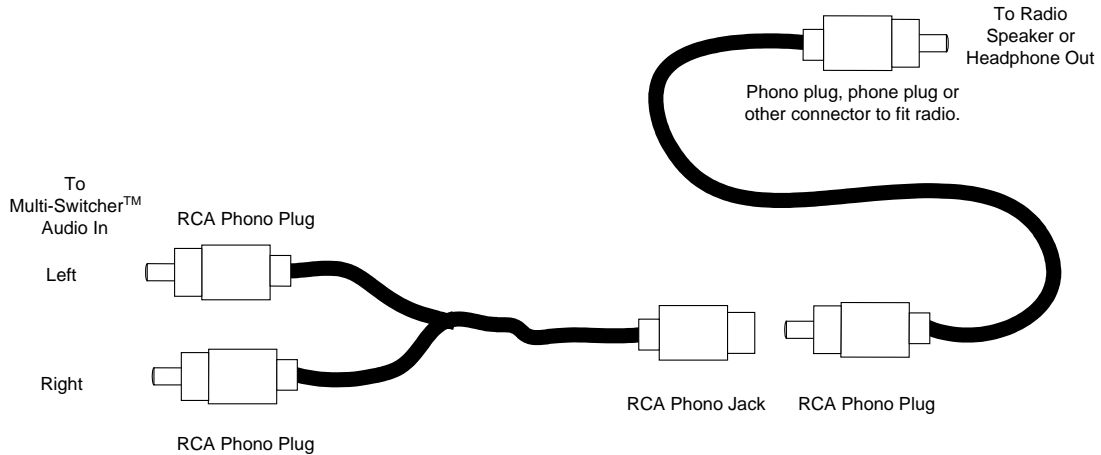

The second method of connecting receive audio to the Multi-Switcher™ is by using the 8-pin Radio connectors on the rear panel. See the chart in section 3.0 for the proper pin-out.

5.0 CW Key connections

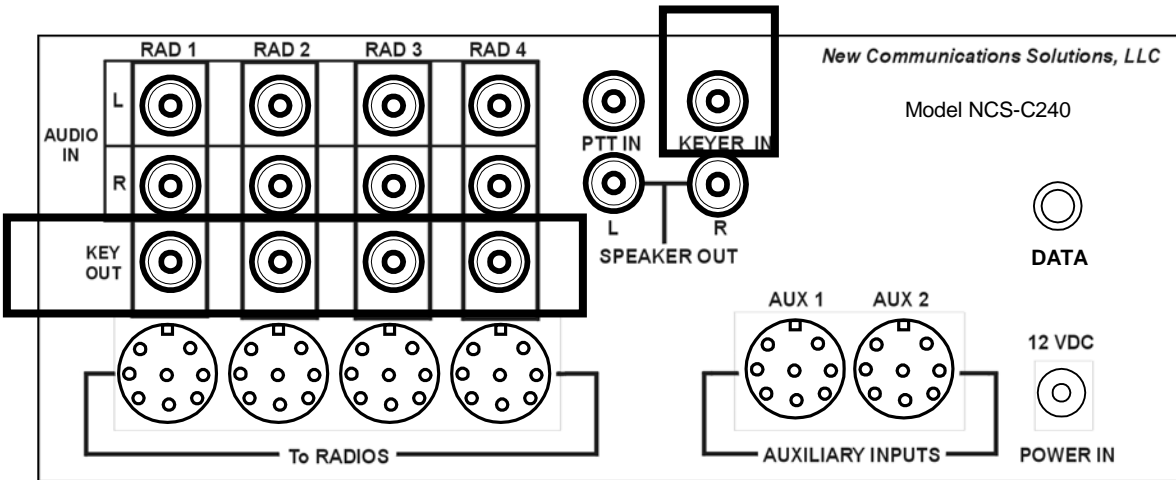

Rear Panel of Multi-Switcher™

The CW Key circuit can be used for special purposes such as controlling other equipment. Contact NCS for information about using the CW Key circuit.

6.0 Foot- or Hand-switch Connections

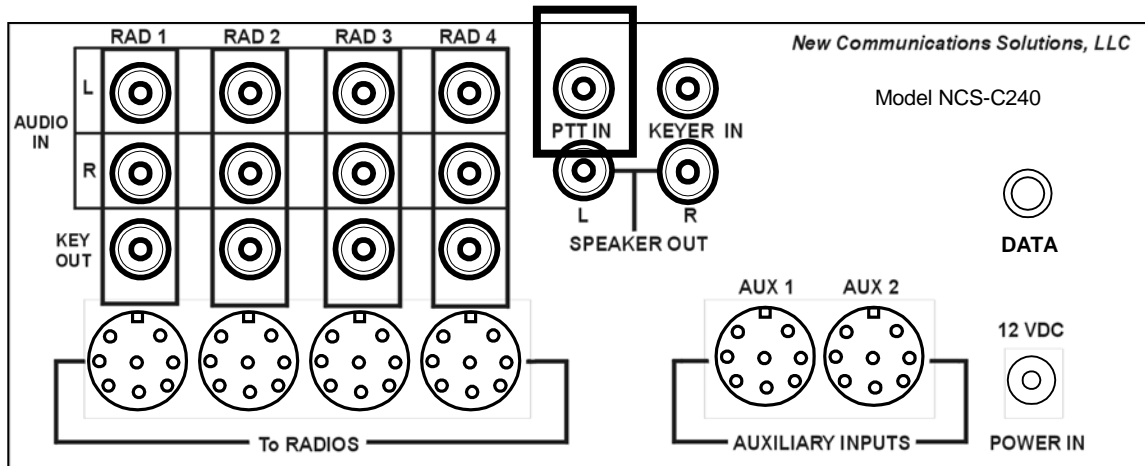

Rear Panel of Multi-Switcher™

A foot-switch or hand-switch can be used with the Multi-Switcher™ by connecting it to the PTT IN RCA Phono jack on the rear panel. The foot- or hand-switch will then operate the PTT for the selected radio. The PTT connection to the radio is made through the Radio connector as shown in section 3.0.

7.0 Setting Transmit Audio Levels

Adjusting the transmit audio levels involves these steps:

- a) Remove the panel covering the Radio Level adjustment controls. This panel is on the front of the Multi-Switcher.
- b) Adjust each transmitter for normal operation using the microphone you normally use with that radio.
- c) Preset all Mic and Aux level controls to minimum (clockwise from inside, counterclockwise from the bottom, of the Multi-Switcher™).
- d) Preset all Radio level controls (front panel) to midrange.
- e) Adjust the Mic or Aux input levels as follows:
 - i. For microphones, connect the microphone to the appropriate connector on the front panel (MIC1 or MIC2) or rear panel (AUX1 or AUX2). Turn the Multi-Switcher™ on and select the microphone using the front panel switches. Then, while speaking loudly into the microphone, adjust the appropriate Mic Level control (MIC1 or MIC2 LEVEL or AUX1 or AUX2 LEVEL) until the LED (LED1A) begins to flash on voice peaks. Repeat for the other microphones. This will balance the microphone input levels so you won't have to make adjustments when switching between microphones.
 - ii. For non-microphone audio sources connected to the AUX inputs, connect the audio source to the appropriate connector on the rear panel (AUX1 or AUX2), turn the Multi-Switcher™ on and select AUX1 or AUX2 on the front panel pushbuttons. Then, while providing undistorted audio to the AUX input, adjust the associated Level control (AUX1 LEVEL or AUX2 LEVEL) until the LED (LED1A) begins to flash. If the audio source is a continuous tone, adjust the associated level control until the LED just begins to light.
- f) Select each radio in turn and adjust the respective output level control (front panel) for normal transmitter operation.
- g) Reinstall the cover over the Radio Level controls on the front panel.

This completes setup and adjustment of the Multi-Switcher.

Note that the Levels for MIC1, MIC2, AUX1 & AUX2 can be readjusted at any time after the cover has been reinstalled on the Multi-Switcher™ by using the access holes in the bottom of the enclosure for the level controls and the Level Monitor LED as shown below:

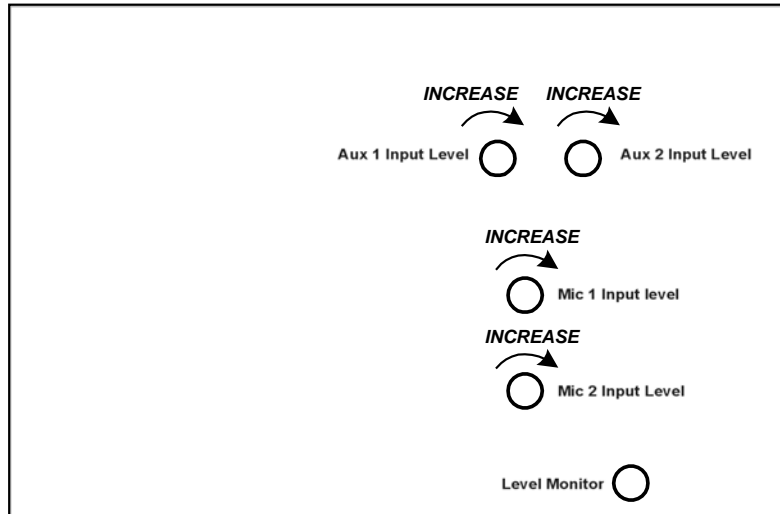

Bottom of Multi-Switcher™ Showing Access Holes for Setting Mic and Aux Levels

8.0 Operating with the Multi-Switcher™

With all desired connections made and microphone programming and levels set, operation of the Multi-Switcher™ is straightforward. Simply select a microphone or other transmit audio source using the AUDIO SOURCE SELECT pushbuttons and select a radio using the RADIO SELECT pushbuttons. To de-select a radio or audio source, you can either select a different radio or audio source or push the selected switch a second time and it will turn off as indicated by the LED on the switch. Note that SOURCE and RADIO selections are maintained when power to the unit is off.

Receive audio can be heard either through speakers attached to the L and R (left & Right) SPEAKER OUT RCA Phono jacks on the rear panel or a set of headphones plugged into the front panel PHONES jack. **CAUTION: Speaker output levels from many radios can be set high enough to cause pain or hearing damage when using headphones. This is not usually a problem when using the radio's Headphone output since most modern radios attenuate the audio at the headphone jack. In any case, the best advice is to always turn the radio volume down before putting on headphones.**

9.0 Serial RS-232 Data

RS-232 CONNECTION

The RS-232 Data connection is a 3.5mm phone jack mounted in the rear of the unit. The pinout for this connector is:

Transmit Data (TD) - Tip
Receive Data (RD) - Ring
Ground (GND) - Barrel

SENDING STATUS

The unit sends it's status at power-on and whenever any button is pushed. The data is sent at 1200N8 as 3 bytes and is in the following format:

	Bit 7	Bit 6	Bit 5	Bit 4	Bit 3	Bit 2	Bit 1	Bit 0
1 st Byte	1	1	0	0	Mic4	Mic3	Mic2	Mic1
2 nd Byte	1	0	0	0	Rad4	Rad3	Rad2	Rad1
3 rd Byte	0	1	0	0	~Rad4	~Rad3	~Rad2	~Rad1

NOTES:

- The lower order bits are set to logic 1 for the selected Radio or Mic in the 2nd Byte.
- The lower order bits are set to logic 0 for the selected Radio or Mic in the 3rd Byte.

The unit will also send it's status upon receipt of an ENQUIRY command.

RECEIVING COMMANDS

	Bit 7	Bit 6	Bit 5	Bit 4	Bit 3	Bit 2	Bit 1	Bit 0
Mic	1	1	X	X	Mic4	Mic3	Mic2	Mic1
Radio	1	0	X	X	Rad4	Rad3	Rad2	Rad1
ENQ	1	1	1	1	0	0	0	0

X = Don't Care

NOTES:

- The lower order bits are set to logic 1 for the selected Radio or Mic in the appropriate Byte. Multiple radios and mics can be selected simultaneously but operation in this mode is not recommended.

9.1 Hum, Noise and Distortion

Your Multi-Switcher was designed with care and uses high quality components and construction. You should not experience any operating difficulties when you follow the setup and use instructions in this manual. If you do experience problems, here is some information that may help you resolve any difficulties.

Hum

Magnetically induced hum can be caused to any modern piece of audio equipment by too close proximity to unshielded power transformers or other equipment that radiates strong AC magnetic fields. You can tell if you have this type of hum by rotating the Multi-Switcher™ left/right, up/down and moving its position. If the hum increases and decreases, then you are experiencing magnetic coupling from an unshielded power transformer or other equipment. The Multi-Switcher™ should be several inches away from equipment that radiates AC magnetic fields.

Another source of hum can be a ground loop. This is a situation when pieces of audio equipment that are connected together do not have their grounds well connected. This results in a voltage difference between the equipment grounds and can be a safety hazard as well as introducing electrical problems. The solution to this problem is to tie all your equipment grounds (usually case or chassis) together with a low impedance RF connection. (NCS has provided connection points on the rear panel of the Multi-Switcher™ to attach a ground if needed. The three threaded holes accept 6-32 screws no longer than ¼ inch.) The best choice for connecting material is a wide braid or copper strap.

Noise

Excessive noise can be caused by many factors. The Multi-Switcher™ uses state-of-the-art low noise amplifier ICs. Nevertheless, even these components can add a bit of noise or “hiss” to an audio signal if not adjusted properly. If you seem to have excessive “hiss” type noise, review the setup and level adjustments you’ve made to the Multi-Switcher. In some cases, increasing the radio’s own mic gain and decreasing the levels from the Multi-Switcher™ may improve the noise level.

Excessive noise can also be caused by ground loops. See the previous “hum” discussion for information on eliminating ground loops.

Distortion

Distorted audio can be caused by one of two situations. The first and most common is improper adjustment of audio levels. Be sure you've adjusted the Multi-Switcher™ level controls as recommended in this manual and that your radio's mic gain control is properly adjusted.

High RF fields in close proximity to the Multi-Switcher can also cause distorted audio. To determine whether this is the problem, connect your transmitter to a dummy load. If the distortion disappears, it is highly probable that strong RF fields are present in the vicinity of the Multi-Switcher. To eliminate RF problems, first make sure you have set up the jumpers and radio cables correctly. Then check that you have a good ground between all pieces of equipment and that your RF ground is low impedance. There are numerous technical publications available that discuss RF interference and grounding problems.

The Use of Audio Isolation Transformers

An effective solution to both DC and RF ground loop problems that affect the quality of the transmit audio is the use of a 600 ohm audio isolation transformer in the radio interface cable audio line. The isolation transformer should be installed (between the Multi-Switcher and the radio transceiver) as shown below. In most cases the use of isolation transformers is not required, but is an effective solution if the problem does exist.

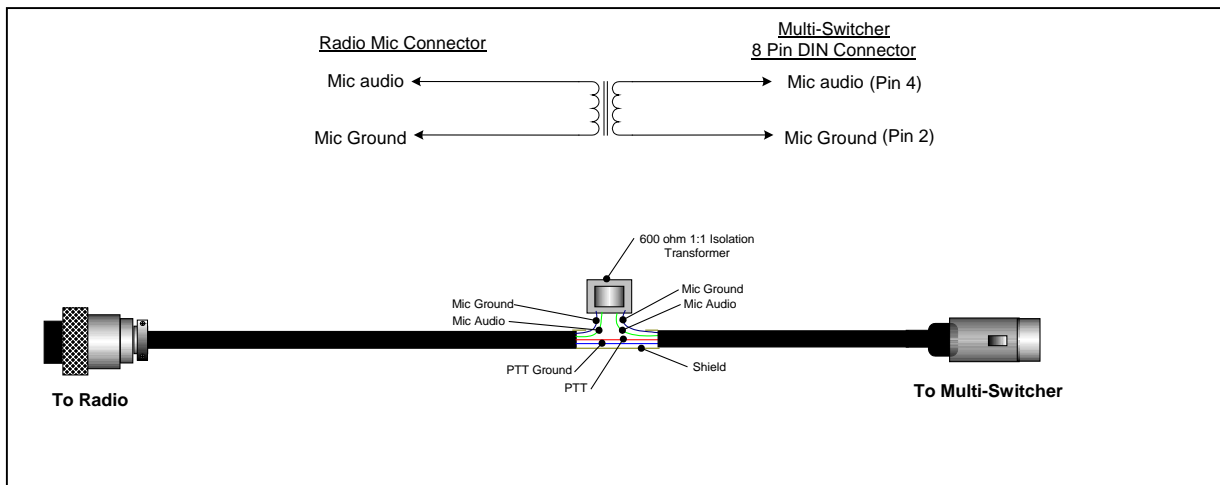

10.0 Getting Help from NCS

NCS wants you to experience trouble free operation of our equipment. If you have any questions, comments or need technical help, please use the following resources:

1. Go to the web site, www.ncsradio.com.
Here you will find the latest instruction manuals, any factory developed modifications and Frequently Asked Questions.
2. Email us at support@ncsradio.com
Be sure to include all pertinent information, e.g. make and model of radios, how they're connected to the Multi-Switcher™, detailed description of any problems, antenna and grounding configurations, etc.
3. Telephone us toll-free at 888-883-5788.

11.0 Multi-Switcher™ Specifications

Front Panel Connections

- Mic 1 Connector – 8 pin standard mic jack
 - Input Impedance: 200Ω, 600Ω, Hi-Z, jumper selectable
 - Type: Most dynamic, ceramic, ribbon, electret and other types.
 - Pin-outs: All 8 pins jumper selectable for Audio, PTT, Ground, Preamp Voltage (+5VDC)
- Mic 2 Connector – 8-pin standard mic jack
 - Input Impedance: 200Ω, 600Ω, Hi-Z, jumper selectable
 - Type: Most dynamic, ceramic, ribbon, electret and other types.
 - Pin-outs: All 8 pins jumper selectable for Audio, PTT, Ground, Preamp Voltage (+5VDC)
- Headphone Connector – ¼ in (6.4 mm) stereo phone jack

Front Panel Controls

- On/Off – Paddle Switch with Yellow Power Indicator LED
- Audio Source Select – Momentary Pushbutton Switch with Red LED Indicator
- Radio 1-4 Select – Momentary Pushbutton Switch with Red LED Indicator
- Radio 1-4 Transmit Audio Level Adjustment

Rear Panel Connections

- Aux 1 & 2 Inputs
 - 8-pin DIN Jacks
 - Input Impedance: 200Ω, 600Ω, Hi-Z, jumper selectable
 - Microphone Type: Jumper selectable for Electret Mic (+5VDC)
 - Pin Assignments: Audio, PTT, Ground, Preamp Voltage (+5VDC)
- Radio 1-4 (connections to radios)
 - 8-pin DIN Jacks
 - Mic Audio Output, common or isolated ground, Lo or Hi Z,
 - PTT
 - Left & Right Receive Audio Input
 - Left & Right Receive Audio Input- RCA Phono Jacks
 - CW Keyer Output, positive keying – RCA Phono Jack
- CW Keyer Input - RCA Phono Jack
- Foot/Hand Switch Input - RCA Phono Jack
- Left & Right Speaker Outputs – RCA Phono Jacks
- Serial RS-232 Data - 3.5mm stereo phone jack
- Power Connector – Anderson PowerPole 15, color-coded.

Power Requirements: 12-15 VDC @ 200 mA max.

Size: 8.5 x 6.2 x 3.3 inches

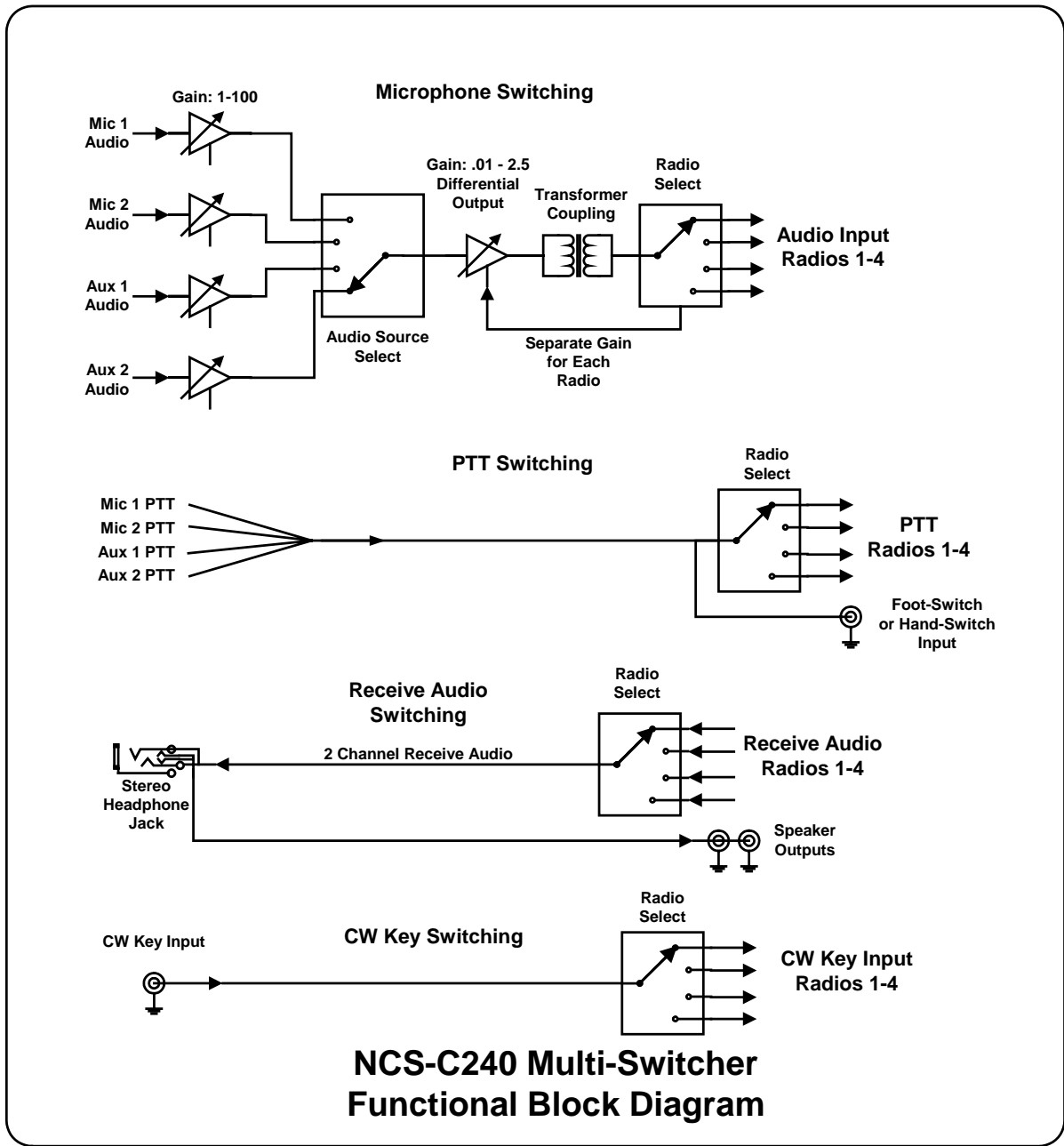

New Communications Solutions, LLC
Limited Product Warranty

All products manufactured by New Communications Solutions, LLC (hereafter referred to as NCS) and purchased from an authorized dealer or purchased directly from NCS will be warranted to be free from defects in material and workmanship for a period of one (1) year from the date of purchase.

NCS' liability under this warranty and the Customer's exclusive remedy is limited to repairing, servicing or adjusting, and/or replacing the defective product returned to NCS within the warranty period. Whether the defective product is repaired or replaced will be at the sole discretion of NCS. The warranty will be voided for products that have been abused, misused, or subjected to abnormal operating conditions as determined by NCS. Further, products damaged by lightning, power surges or force majeure events are not covered under this warranty.

If, in the Customer's estimation the product appears to be defective and is within the warranty period NCS should be notified as to the nature of the defect. If the product appears to be covered by the terms of the warranty, NCS will promptly communicate a return authorization number and shipping instructions to the Customer. When returning a product for repair/replacement under warranty the proof of purchase or a copy thereof must be returned with the defective product. NCS at its discretion may deny warranty in the absence of proof of purchase. Acceptable proof of purchase include bill of sale, cancelled check or credit card receipt. Evidence of alteration of the proof of purchase document shall be reason to immediately void the terms of the warranty.

For those products returned that prove to be defective and covered under the warranty, the Customer will bear the cost of shipment for the return of the product to NCS. Collect shipments will not be accepted. NCS will bear the cost of shipment for return of the product to the Customer after repair/replacement. Mode of shipment for return to the Customer will be determined by NCS. Should examination reveal that the product is not defective, NCS will notify the Customer and request return shipping instructions and NCS will be due all shipping expenses. In the event that the examination reveals that the product is defective, but for any reason is excluded from this warranty, NCS will prepare a quotation of the cost to repair, and will communicate same to the Customer. In the latter event, NCS will be due all shipping charges incurred for return of the product to the Customer.

The Customer may attempt to repair a defective product under warranty provided authorization to do so is received from NCS Technical Support. NCS will supply replacement parts free of charge for authorized Customer repairs provided that the defective part along with the proof of purchase is submitted to NCS. NCS will pay postage and handling for replacement parts provided the above terms are met. The product warranty under these circumstances will remain in force for the life of the warranty.

EXCEPT FOR THE EXPRESS WARRANTIES STATED IN THIS WARRANTY, WHICH ARE EXCLUSIVE, NCS DISCLAIMS ALL WARRANTIES ON PRODUCTS SOLD HEREUNDER, INCLUDING ALL IMPLIED WARRANTIES OF MERCHANTABILITY AND FITNESS FOR A PARTICULAR PURPOSE. UNDER NO CIRCUMSTANCE IS NCS LIABLE FOR CONSEQUENTIAL DAMAGES TO PERSON OR PROPERTY AS A RESULT OF THE USE OF ANY NCS PRODUCTS.

The Customer may have additional rights beyond those specifically outlined in this document based on individual state laws.